

DIM Design & Installation Manual
Swisspearl Largo Gravieral



General information, Program		Remarks, system, validity, ordering material, rain screen cladding	3
	Panel sizes	Overview panel, sizes Application cutting	4-5
		Ordering material, Software support, Positioning, Cutting from CAD	6
	Adhesive	Adhesive application	6
	Sigma 8	Gravial Sigma 8	7
	Accessories	Fasteners	8
		Joint material	9
	General remarks	Terminology	10
		Corner zone, Application, Windload	11
	Design		Insulation, Rear ventilation, Open joints
		Ventilation openings, building dilatation	11
		Panel support, Compatibility, Sub-frame	12-13
		Reference Lines	14
Metal panel support		Distances to panel edge, joints, fixed and sliding points	15
		Aluminum, steel sub-frame	16-19
		Drilling and riveting, fixed point, sliding point, fastener distances	20
		Windload guidelines	21-22
		Single span panel	23
		Swisspearl Largo Gravial portrait/landscape	24-26
Details		Outer corner, Inner corner, Window jamb, window sill	27-29
Swisspearl Gravial		Window head, bottom detail, coping detail	30-32
Timber panel supports		Distances to panel edge, panel joints	33
		Timber quality, screws, ventilation cavity	33
		Fastening on timber battens,	34-36
		Horizontal section, vertical joints at windows, fastener distances	37-38
		Windload guidelines	39-40
	Single span panels, Installation	41	
Installation	Swisspearl Gravial	Swisspearl Largo Gravial portrait/landscape	42
	Details	Outer corner, Inner corner, Window jamb, window sill	43-45
		Window head, bottom detail, coping detail	46-48
	Storage on site	On site storage, Guideline, Stacking	49
	Cutting, Tools	Fabrication, Cut outs, Sealer, tools	50
	Cleaning	Cleaning procedures, Masking tape	51

Remarks

This DIM (Design + Installation Manual) provides technical information regarding design and installation. Refer to area manager and local distributor for further information such as:

- Terms of delivery
- Pricing
- Products and colors
- Lead time, etc.

More general information available on www.swisspearl.com

CH- 8867 Niederurnen
Tel. +41 55 617 11 60
Email: info@swisspearl.com

Validity of DIM

Please consult your local distributor and or the Technical Advisor prior to the commencement of shop drawings or installation for the most current DIM guide. The current DIM can always be found at www.swisspearl.com. All previous DIM guides should be disregarded and are no longer valid

Product warranty

20 year warranty for the functional quality of panels and accessories, provided that the installation is in full compliance with this DIM.

Maritime conditions

Maritime conditions call the use for stainless steel rivets. Those may be used on steel or anodized aluminum sub frame. Maritime conditions are considered 50m to 1km (0.03 to 0.6 miles) from the sea. Material specification for sub frame, fasteners and accessories to cater for maritime conditions according to local standards.

Advantages of fiber cement products

- Maximum protection against weather
- Excellent longevity
- Easy installation in any climate
- Almost no maintenance required
- Proven details
- No cracks, paint or sealant problems
- High sustainability
- Non combustible

Project specific ordering

Subtle visual differences may occur between product batches. Therefore we recommend ordering by job or specific elevation if ordering in phases.

Disclaimer

The information and recommendations contained in this Design & Installation Manual ("DIM") are offered as a service to architects, constructors, installer and other persons involved with our products and are not intended to relieve them from their own responsibility. The information and recommendations provided herein are believed by Eternit (Schweiz) AG ("Eternit") to be accurate at the time of preparation of this DIM, or obtained from sources believed to be generally reliable. Eternit makes no warranty concerning the accuracy of the content of this DIM and shall not be liable for claims relating to any use regardless of whether it is claimed that the information or recommendations are inaccurate, incomplete, or otherwise misleading. The information and recommendations herein are intended to be used with the judgment and experience of professional personnel competent to evaluate the significance and limitations of the material contained. Eternit expressly disclaims any guarantees or warranties, expressed or implied, for anything described or illustrated herein and assumes no responsibility or liability for damages of any kind, including - without limitation - bodily harm, injury or damage to property inferred from this DIM or the use of the materials described herein.

Overview panel sizes

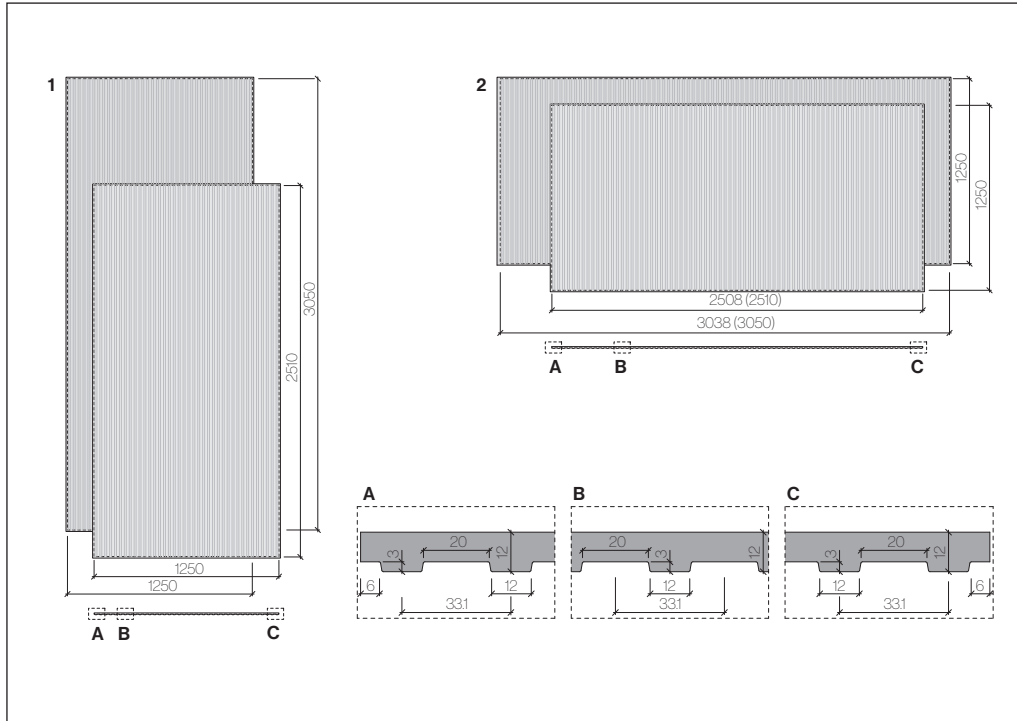

Gravia 9/12 mm thick panels - max. net panel sizes

Product data

- Density > 1.8g/cm³
- Modulus of elasticity ca. 15'000 MPa
- Characteristic value for bending strength (average) ca. 22.4 MPa
- Thermal expansion coefficient 0.01 mm / m / °K
- Fire classification according to NFPA 285 EN 13 501-1 & A2-s1, d0
- Frostresistance and durability under EN 12467
- Thermal range - 40°C to + 80°C

Overview of colors and panels available see: «Swisspearl Design Solutions, products and system».

Variants of structure

Further design router variants on request.

- 1** Portrait Panel Typ L
- 2** Landscape Panel Typ Q

The type must be specified when ordering whole panels. (cut to size on site)

Overview

Swisspearl Largo Gravia		Nobilis Carat	
Thickness	mm	9/12	
Weight	ca. kg/m ²	24.1	
Format Untrimmed panels	max. net panel sizes		
	Landscape	Portrait	
3070 × 1270	3038 × 1250 (3050 × 1250)	1250 × 3050	■
2530 × 1270	2508 × 1250 (2510 × 1250)	1250 × 2510	■

Additional panels without engraving

Supplementary panels are from the standard Carat and Nobilis range available.

Application

Swisspearl Largo panels can be attached to vertical timber or metal profiles. Suitable for new facades or existing cladding renovations.

Untrimmed full size panels

Untrimmed panels will only be provided to approved fabricators. Untrimmed Swisspearl Largo panels must be trimmed 10 mm on all four sides.

Signage, light fittings, etc.

Provide structural attachment points behind the panel as required. Leave generally min. 6 mm (¼") free gap between panel edge and installation - so as not to constraint the panel movement.

Sealed cut edges

All panel edges cut on site or at fabricators workshop must be sealed by LUKO sealer, provided by Swisspearl.

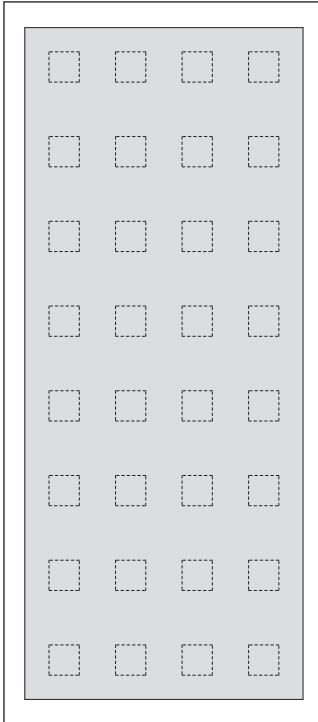
Adhesive application**Adhesive technology**

Specially ordered ARSB panels are signified by printed squares on the backside of the panel. Please consult with your adhesive manufacturer prior to installation. Zenor panels only available for face fastened system.

General requirements

Glue manufacturer's instructions for use must be strictly followed regarding all aspects, including:

- Cleanliness of panels and support profiles
- Panel and air temperature
- Air moisture content
- Etc.

Support profiles

- For exterior application the panels may be glued to aluminium supports only.
- Sub framing to be approved by glue manufacturer prior to stating the installation.

Panel ordering

Panels ordered for adhesive application are called ARSB and are available upon request at time of order. Standard Swisspearl panels cannot be used for adhesive application.

Warranty

Panel manufacturer provides functional warranty for the panels only. Warranty for the attachment of the panels to be obtained by glue manufacturer.

Character

Large format Largo Gravial fiber cement facade panels, with a concealed system, consists of a high quality design, which represent the pure principle of a ventilated facade without any visible attachments.

System description

The Sigma 8 system consists of 9/12 mm thick Largo Gravial panels with a maximum size of 3050 × 1250 mm; with undercut anchors on the rear side and attachment cleats that are fastened to vertical sub frame profiles made out of timber battens or metal profiles out of aluminium or galvanised steel. The drilling of the undercut holes and the gluing of the anchor inserts into the holes requires high precision and must be carried out at the factory in Niederurnen, Switzerland.

All attachment cleats are installed on site. The panels are cut to size and packed onto pallets at the factory according to dimensions provided by the customer.

System Sigma 8

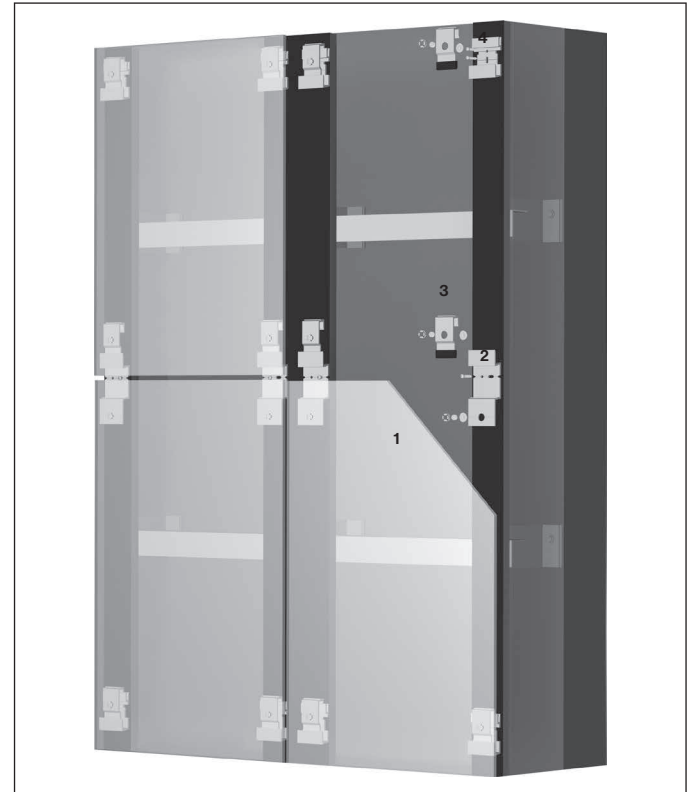

- 1 Swisspearl Largo Gravial panel 9/12 mm
- 2 Omega cleat S8
- 3 panel clip S8
- 4 U-Cleat

Fasteners

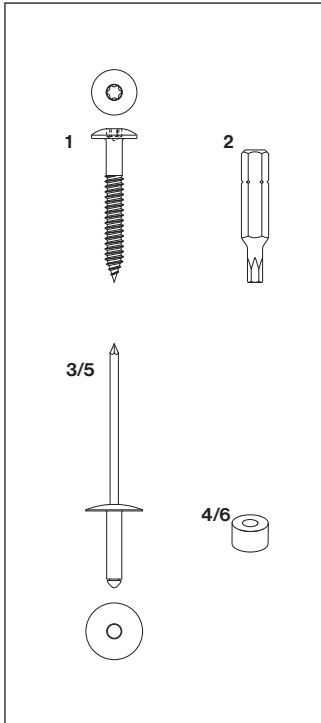

To timber battens

- 1 Screw, inox, saucer head Ø 12 mm, T20 drive, blank or powder coated
4.8 × 30, **4.8 × 38 mm**
4.8 × 44, 4.8 × 60 mm
- 2 Torx bit T 20 W

To aluminium profiles

- 3 Aluminium rivet head Ø 15 mm, blank or powder coated
 - 4.0 × 18-K15, 8-13 mm grip range
 - 4.0 × 24-K15, 13-18 mm grip range
 - 4.0 × 30-K15, 18-23 mm grip range
- 4 Fixed point sleeve aluminum type 8

To steel profiles

- 5 Stainless steel rivet, head Ø 15 mm, blank or powder coated
 - **4.0 × 18-K15, 9-14 mm grip range**
 - 4.0 × 23-K15, 14-19 mm grip range
- 6 Fixed point sleeve stainless steel type 8

Maritime conditions

Maritime conditions call the use for stainless steel rivets. Those may be used on steel or anodized aluminum sub frame. Maritime conditions are considered within a distance of 1 km (0.6 miles) from the sea. Material specification for sub frame, fasteners and accessories to cater for maritime conditions according to local standards.

Joint material

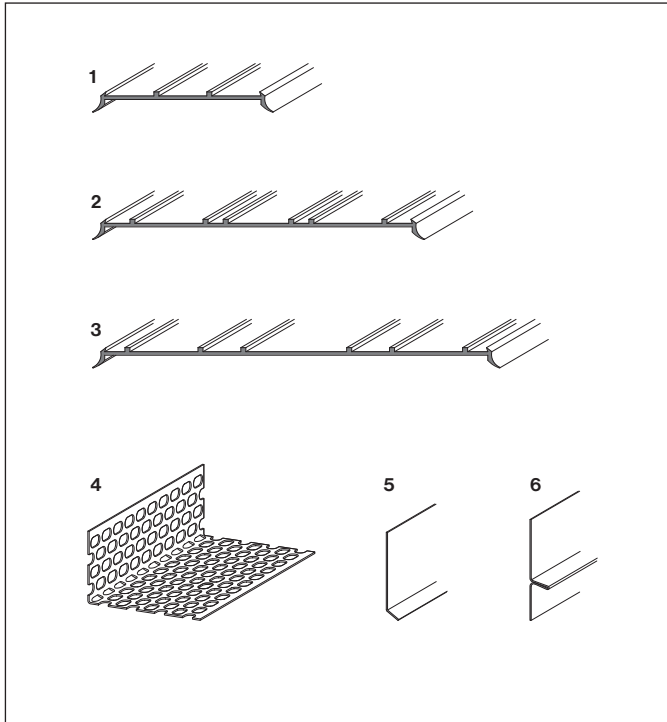

- 1 EPDM band, black, 60 mm wide for intermediate supports with side lips, in 50 m rolls
- 2 EPDM band, black, 100 & 120 mm wide for butt joints with side lips, in 50 m rolls
- 3 EPDM band, black, 150 mm wide for inner and outer corners with side lips, in 25 m rolls
- 4 Ventilation profile, raw aluminum or standard colors, 50 × 30 mm, 70 × 30 mm, 100 × 40 mm. 2500 mm long, 0,6 mm thick
- 5 L-flashing, stainless steel, millor powder coated, 0,5 mm thick 2510 / 3050 mm long
- 6 Horizontal joint flashing, aluminium, powder coated black, 0,5 mm thick 2510 / 3050 mm long

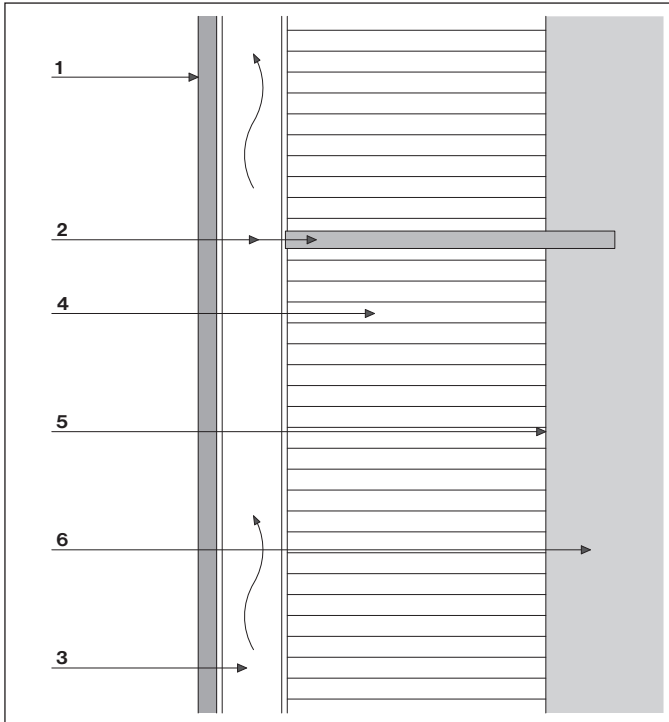
Terminology

Vertical section

Rear ventilated cladding

The design principle involves the deflection (screening) of the rain water. As the panel joints are not sealed, minimal amounts of water can gain access into the air cavity behind the panel. The cavity is naturally ventilated by vent gaps at bottom and top, so that any moisture will evaporate naturally by thermal action.

Cladding (1)

Panels with open or closed joints, in one plane or lapped.

Sub framing (2)

To support the cladding dead and wind load generally vertical panel supports in timber or metal.

Ventilation cavity (3)

Cavity behind panel with ventilation gaps at bottom and top.

Thermal insulation layer (4)

To increase the thermal insulation capacity of the exterior wall.

Substrate (5)

Face of exterior wall, such as plaster, concrete, exterior sheathing, wind proofing layer, etc.

Exterior wall (6)

Brick, concrete, wood and steel studs

Corner zone

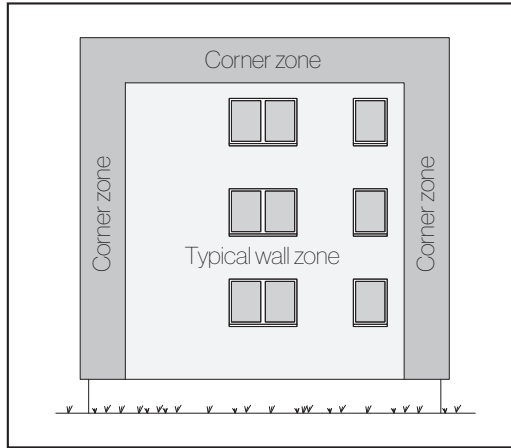

Wind load zones
 As per scheme there are two wind load zones: The corner zones generally are subject to increased negative wind load (suction) due to turbulence at the edges of the building. The applicable wind load values must be determined in the cladding specification.

Min. manufacturer cavity depth:

Mandatory for issuance of the warranty letter.

Cladding height	min. cavity
< 6 m	20 mm
6 - 30 m	30 mm
> 30 m	40 mm

Application

Swisspearl cladding panels can be attached to vertical supports made of timber, aluminium or steel.

Windload

Always consider local standards when determining windloads and related panel fastener distances. This is especially important for tall buildings, for buildings with special shapes and for high wind exposure areas.

Ventilation cavity

Building tolerances must be allowed for. The cavity may not be reduced by horizontal profiles or any stray objects such as loose insulation and other materials.

Ventilation cavity

Minimum airflow at the backside of the panels should be 100% free of obstructions with no less than 200 cm² of vertical airflow (Min 20 mm System depth) behind panels. Minimum air flow at base and top of walls is required to have at least 60% unobstructed ventilation if using ventilated profiles.

Ventilation cavity with perforated horizontal subframe components

Min ventilation gap to be 40 mm. Horizontal profiles should allow min. 75% airflow. In advance please contact your Technical Service for approval.

Building expansion joints

The buildings structural expansion joints should be considered when designing subframe systems. Structural expansion joints must be applied to sub frame and cladding as provided to the building structure.

Panel support

Panel must be supported on an even surface. If perforated angles are placed between the panel and batten/vertical profile the closure piece must not exceed 0.8 mm. Perforated angles have to allow ventilation entrance with a min. perforation of 60%. The use of an aluminium mesh is possible. It has a high ventilation ratio, thin material thickness (no push out of panel) and is easy to install.

Material compatibility

Untreated aluminum material such as Window sills, frames, etc. is not compatible with cement and must be protected against dust from drilling panels, etc. Aluminum components are to be used in anodized or powder-coated or Kynar Coated for exterior applications with protective films.

- 1 Swisspearl Largo Gravia 9/12 mm
- 2 Fastener
- 3 Panel support
- 4 Perforated angle
- 5 Recess

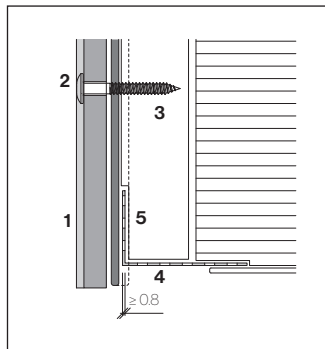
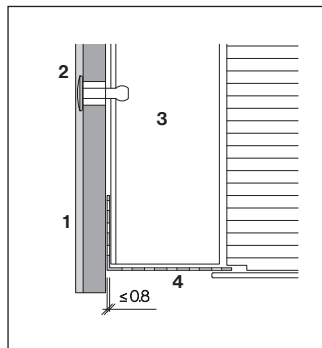
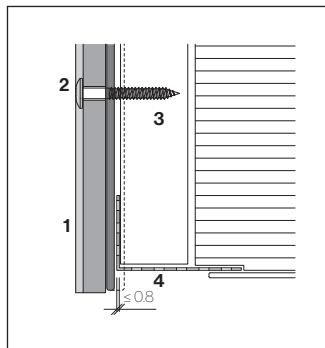
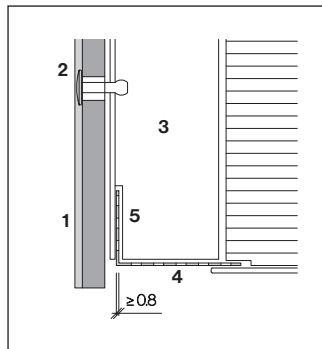
Timber battens**Metal profile****Sealant material**

Generally to keep the cladding maintenance free the use of sealants should be avoided. Where the use of sealant is unavoidable Polyurethane, Acrylic or Hybrid Polymer products would be best suitable. Before applying any sealant to fiber cement material the compatibility must be checked as certain materials leave permanent staining on panel surface.

Sub frame types

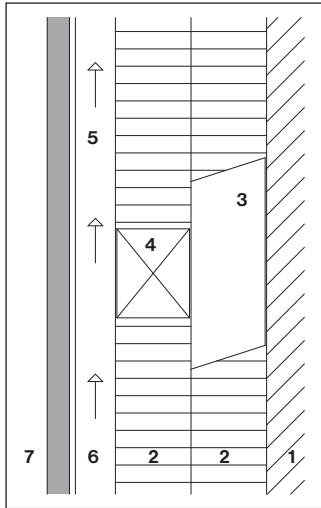

Timber / timber

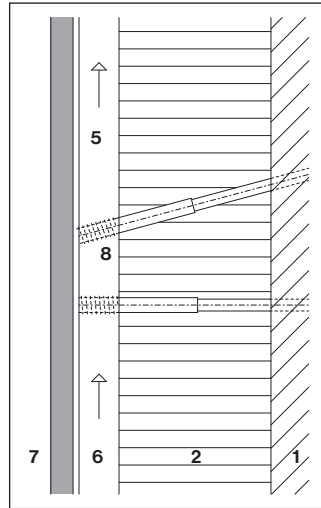

Timber / spacer screw

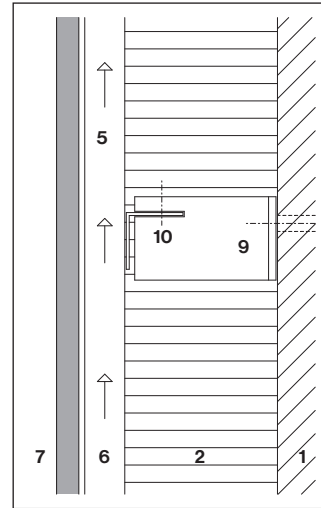

Metal / timber verticals

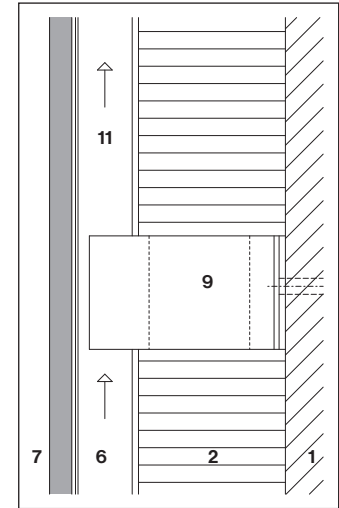

Metal

- 1 Substrate
- 2 Thermal insulation
- 3 Vertical batten
- 4 Horizontal batten
- 5 Panel support
- 6 Vent cavity
- 7 Swisspearl Largo panel

- 8 Spacer screw
- 9 Bracket
- 10 Horizontal batten
- 11 Vertical batten

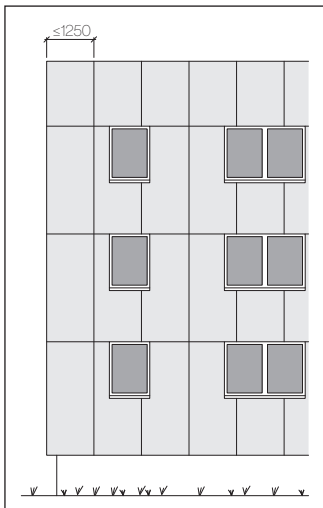
Reference lines

Portrait installation

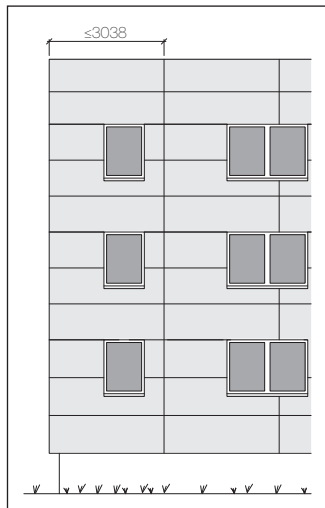

Landscape installation

Reference lines

The planning of vertical joints can be done with a maximum panel usable dimension. Aesthetically the building corners or certain reference lines can be divided. The lintels should be considered as horizontal reference lines.

Panel width

The minimum panel width for portrait Gravia panels is ≥ 300 mm. In case of continuous vertical stripes, control that the Gravia lines are even. The height of the landscape Gravia panel is ≥ 300 mm.

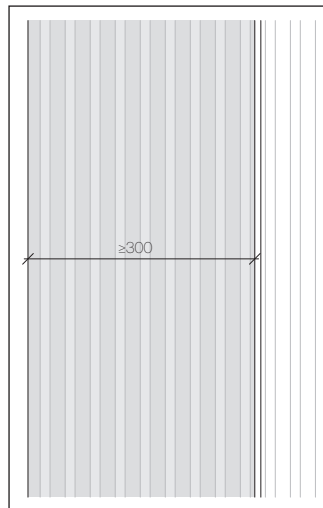
Min. panel width

Min. width portrait

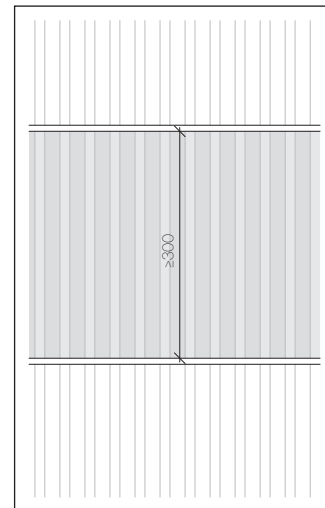

Min. width landscape

Fastener distance

For fastener distances on Gravia panels ≥ 300 mm, see Largo large size format documentation.

Should you consider a smaller width, please get in touch with your Swisspearl Technical Advisor.

Swisspearl rivet

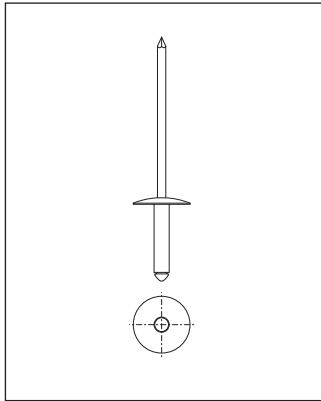

Swisspearl rivet Ø 15 mm 4.0×18-K15

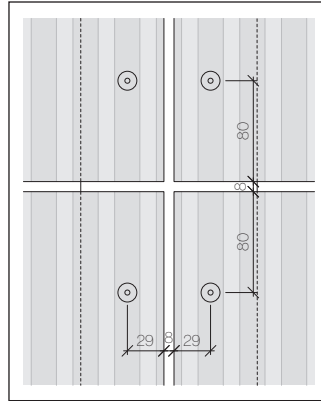

Panel edge distances

Holes in panel for rivets

Diameter 9.5 mm

Standard edge distances

Horizontally 29 mm

Vertically 80 mm

Minimum edge distances

Horizontally 29 mm

Vertically 60 mm

Maximum edge distance

Horizontally and vertically 100 mm

Panel joints

Typical panel joint is 8 mm, this allows panel scraps to be used as spacers. Wider joints will make any inaccuracies in the installation less noticeable.

Fixed, sliding points

Each panel must be fastened by 2 fixed points in the panels center to support the panels deadload. All other rivets are sliding points.

Drill holes Ø 4.1 mm to metal profiles

Use centering drill gauge so the holes will be concentric to the Ø 9.5 mm hole in the panel. Use drill bit type A for aluminum profiles and type S for steel.

Sub-frame engineering

Engineer / contractor is responsible for the design and installation of all sub frame parts including all pertaining fasteners.

The sliding point connection is **NOT** meant to accommodate building drift or seismic movement.

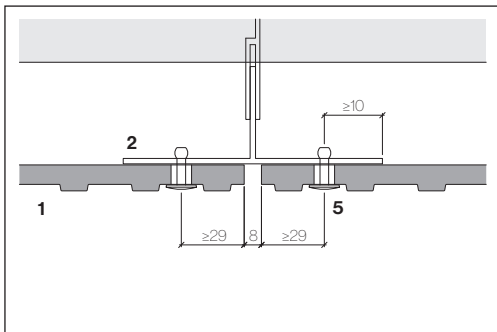
Sub frame examples

T-Profile 120 mm
Continuous Graviatgrid

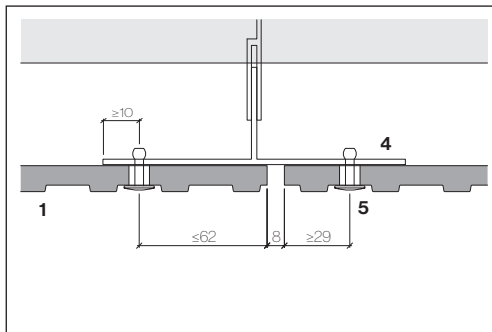

T-Profile 140 mm
Individual Graviat grid

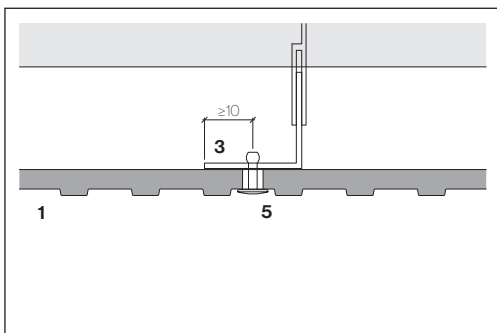

Intermediate support L-profile 45 mm
Continuous Graviat grid

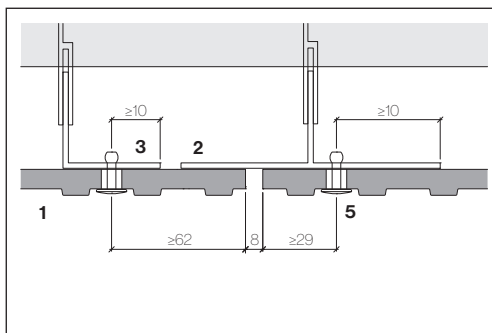

T-profile 120 mm and L-profile 45 mm
Individual Graviat grid

- 1 Swisspearl Largo Graviat 9/12 mm
- 2 Vertical profile T-profile 120 mm
- 3 Intermediate profile, L-profile 45 mm
- 4 Vertical profile, T-profile 140 mm
- 5 Rivets 4.0 × 18-K15

Panel Planning

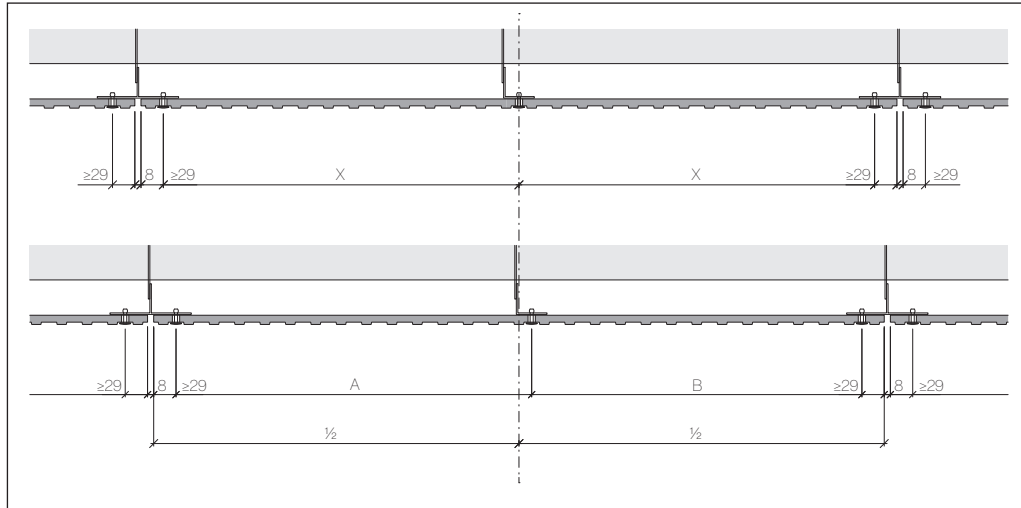

Jobsite fabrication

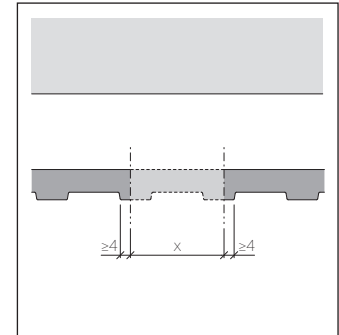

Onsite Gravial fabrication

Gravial cutting

When Gravial panels are cut on site, please note that minimum edge distance of 4 mm remains.

All cut edges must be afterwards treated with Luko sealant.

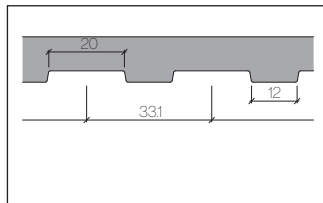

Detail engraving Gravial grid

Installation planning

The arrangement of the sub-frame will always depends on the grid of the engraving.

Calculation example:

Panel width minus lateral edge distance due to raster engraving = number of millings

Even = X

Uneven = A; B

Aluminium profiles

Aluminium thickness should be a min. of 2 mm. Profiles should not exceed 3 m and profile breaks should coincide with panel joints.

Aluminium rivet

4.0 × 18 - K15 rivet, head Ø 15 mm, powder coated or blank, grip range 8 - 13 mm.

Staggered horizontal panel joints

Use two vertical profiles to vertical panel joint so that each can be broken on its horizontal panel joint level.

Black panel joints

Panel joints read as shadow lines. It is recommended to blacken the metal where visible, with paint or PVC paint tape.

Steel profiles

Steel panel supports to be min. gauge 18 (1.27 mm / 0.05") to obtain nominal pull out value. Profiles should not be longer than 6 m (20').

Stainless steel rivet

4.0 × 18 - K15 rivet, head Ø 15 mm, powder coated or blank, grip range 9 - 14 mm.

Sub-frame engineering

Engineer / contractor is responsible for the design and installation of all sub frame parts including all pertaining fasteners.

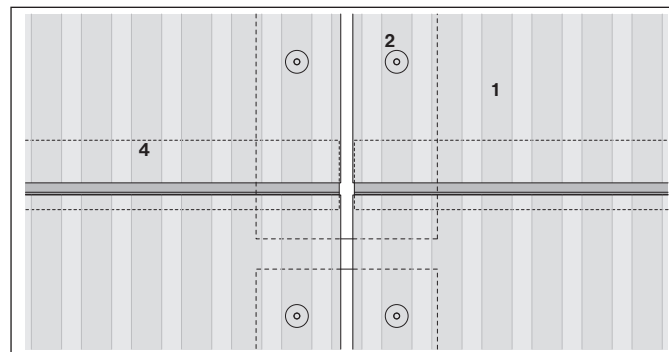
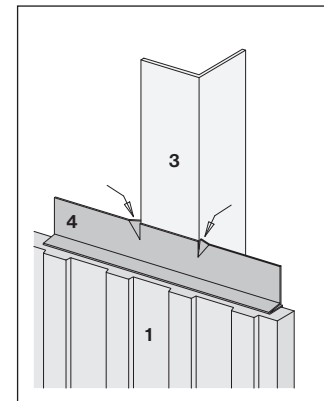
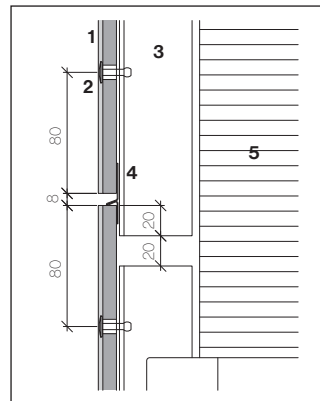
Horizontal joint

- 1 Swisspearl Largo GraviaI 9/12 mm
- 2 Rivet
- 3 Panel support profile
- 4 Joint flashing (optional).
L = panel width - 2 mm.
- 5 Thermal insulation

Any breaks to panel support profiles must be located at panel joints as shown. Flashing cut at one vertical as shown to prevent lateral dislocation of flashing.

Horizontal section

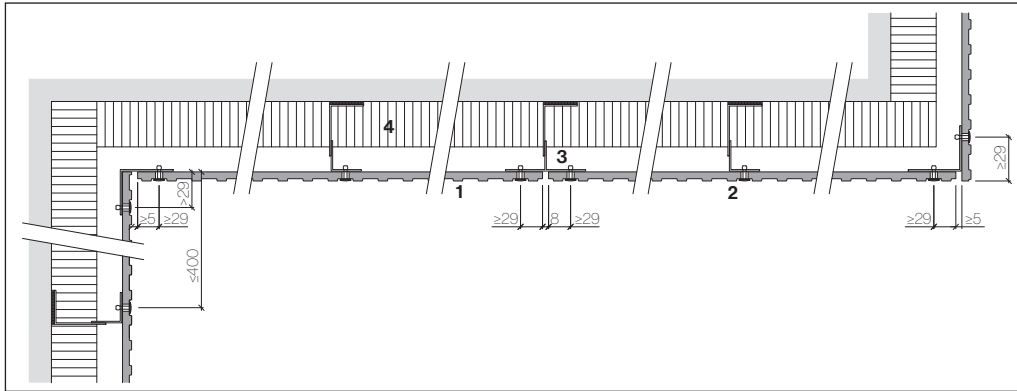

Panel may be cantilevered max. 400 mm.

- 1 Swisspearl Largo Graviat 9/12 mm
- 2 Rivet
- 3 Aluminum profile
- 4 Thermal insulation

Rivet installation

Use rivet gun GESIPA ACCUBIRD or similar. Do not use pneumatic equipment. Use centering drill gauge with drill bit $\varnothing 4.1$ mm to obtain concentric hole [A/3].

Fixed point for Aluminum Sub-frame

Fixed point for Aluminum, Type 8 $\varnothing 9.4$ mm [B/4]

- Rivet head $\varnothing 15$ mm 4.0×18 -K15, blank or powder coated, grip range 8-13 mm

Fixed point for Steel Sub-frame

Fixed point steel A2, Type 8, $\varnothing 9.4$ mm [B/4]

- SS Rivet, head $\varnothing 15$ mm, 4.0×18 -K15, blank or powder coated, grip range 9-14 mm

Each panel must be fastened by 2 fixed fastening points in the panel center, installed first. All the others are sliding points.

Sliding points for Aluminum Sub-frame

Use centering drill gauge with drill bit $\varnothing 4.1$ mm to obtain concentric hole [C/5]

- Alu Rivet, head $\varnothing 15$ mm 4.0×18 -K15, blank or powder coated, grip range 8-13 mm. Sliding points for Steel Sub-frame use center drill gauge with drill bit $\varnothing 4.1$ mm to obtain concentric hole [C/5]

Sliding points for Steel Sub-frame

- Sliding points for Steel Sub-frame. Use centering drill gauge with drill bit $\varnothing 4.1$ mm to obtain concentric hole [C/5]
- SS Rivet, head $\varnothing 15$ mm, 4.0×18 -K15, blank or powder coated, grip range 9-14 mm

- 1 Support profile
- 2 Swisspearl Largo 8 mm
- 3 Concenter drill gauge
- 4 Fixed point sleeve, type 8
- 5 Rivet 4.0×18 - K15

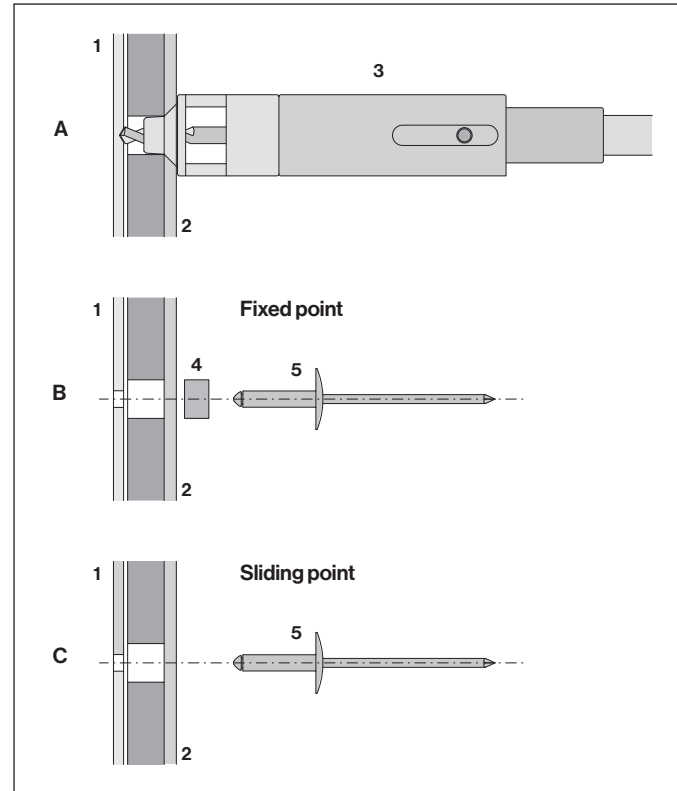

Metal sub frame - Gravia! 9/12 mm façade panels - rivet distances

Characteristic value of wind suction (according to European standards)		Design value of wind suction (including a chosen safety coefficient of 1.5)		Recommendation for maximal spacing d (distance between rivets or screws)			
				Vertical panel (portrait)		Horizontal panel (landscape)	
kN/m ²	psf	kN/m ²	psf	horizontally mm	vertically mm	horizontally mm	vertically mm
-0.70	-13.90	-1.0	-20.9	600	725	725	530
-1.00	-20.90	-1.5	-31.3	600	590	675	530
-1.30	-26.50	-1.9	-39.7	600	490	520	530
-1.80	-37.60	-2.7	-56.4	400	490	430	370
-2.30	-48.70	-3.5	-73.1	400	420	400	370
-2.70	-55.70	-4.0	-83.5	400	330	370	370
-3.30	-69.60	-5.0	-104.4	300	370	370	280
-4.00	-83.50	-6.0	-125.3	300	330	330	220

Above table is a guide line for 2 or more fasteners in vertical and horizontal direction. The spacings originate from 1230 × 3050 mm full size panels with equal distances between rivets. Data may be interpolated.

Metal sub frame - Gravia 9/12 mm façade panels - rivet distances**Engineering responsibility**

The spacings in above table are provided as indication. For the actual cladding design a locally licensed engineer shall assume responsibility for calculation and verification.

Panel data

- Modulus of elasticity
MOE ca. 15'000 MPa
- Characteristic value of bending strength (average: lengthwise / crosswise) or MOR (average) 22,4 MPa
- Density > 1.8g/cm³

Characteristic values**Resistance of aluminum and steel rivets 4.0 × 18 K15**

Position	Distance between fasteners (spacing)
	600 mm
Middle	2100 N
Edge	1350 N
Corner	1050 N

The data was evaluated according to ETAG 034 using 9/12 mm Gravia panel, and includes no safety factor. Diameter of panel hole must be 9.5 mm, and rivet head must be 15 mm. Min. thickness for steel profiles to be 1.27 mm, and 2 mm for aluminum. Edge distances 29 mm horizontally, 80 mm vertically. The data may be interpolated.

Single span no intermediate support

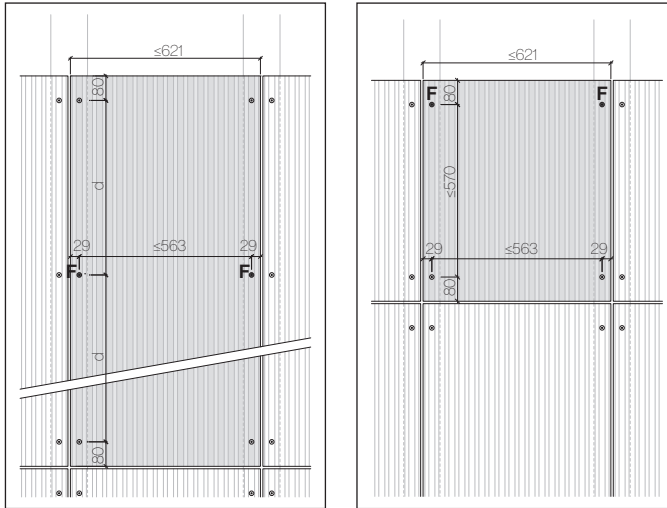

Single span

Fixed point Ø 9.5 mm [F]

Sliding point Ø 9.5 mm

Soffit panels

Fastener distances for soffit panels and suspended ceilings not to exceed 500 mm.

- Fixed point Ø 9.5 mm [F]
- Sliding point Ø 9.5 mm

Max. distance between fasteners for single span panels 570 mm, unless smaller distances is required by high wind load as per table of fastener distances.

If more than 5 single span panels are ad- joining each other - the chain of fixed points must be interrupted by a different configuration of the fixed points.

Consult with technical advisor.

Design I Metal supports

Swisspearl Largo Gravia

Sample rivet layouts, final layout to be determined by a local structural engineer.

Swisspearl Largo vertical panel (portrait)

Swisspearl Largo vertical panel (portrait)

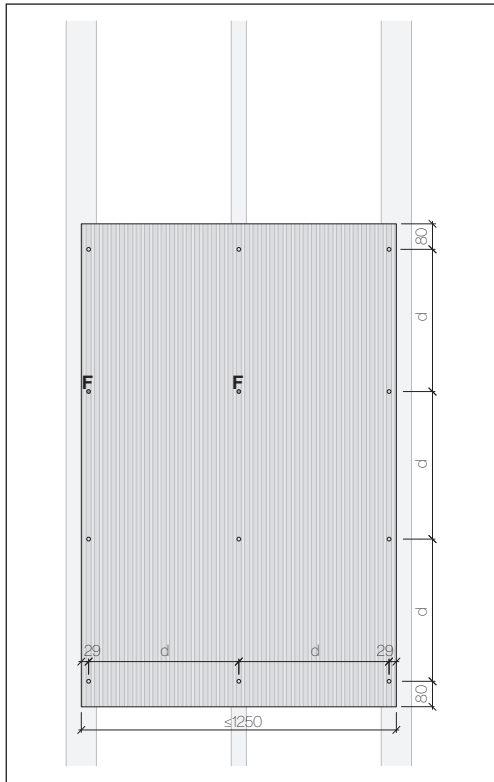
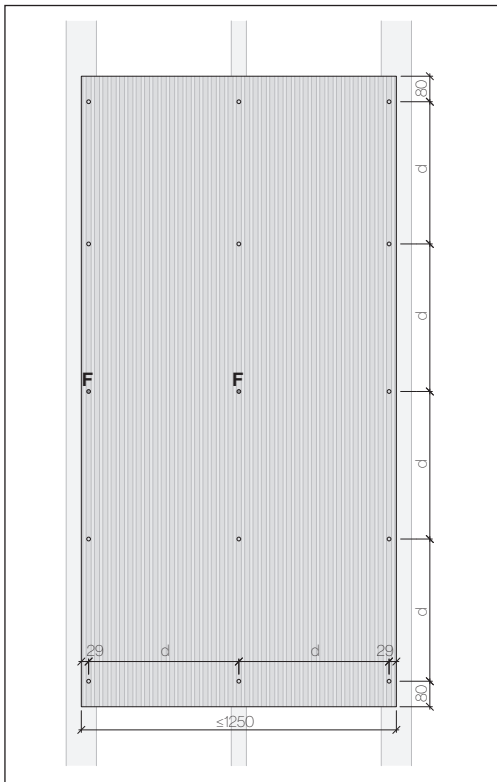

- Fixed point
 - Sliding point
- Ø 9.5 mm [F]
Ø 9.5 mm

Fixed points [F] center and left.

If no rivet at half height go with [F] to row above.

Design | Metal supports

Sample rivet layouts, final layout to be determined by a local structural engineer.

Swisspearl Largo horizontal panel for odd number of rivets

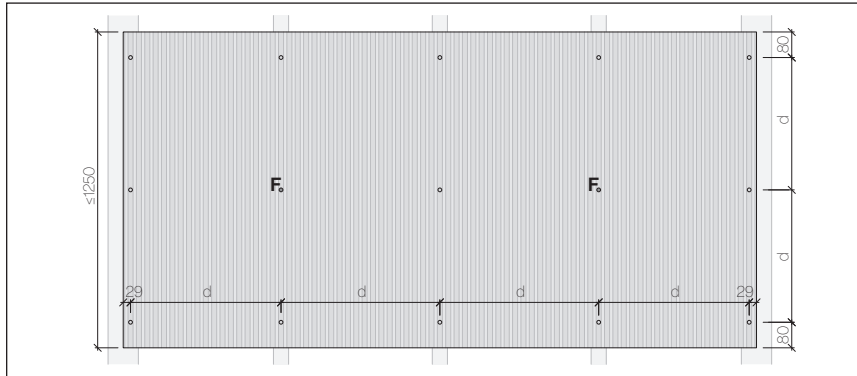

Between fixed points, the max. distance can be 1 sliding point

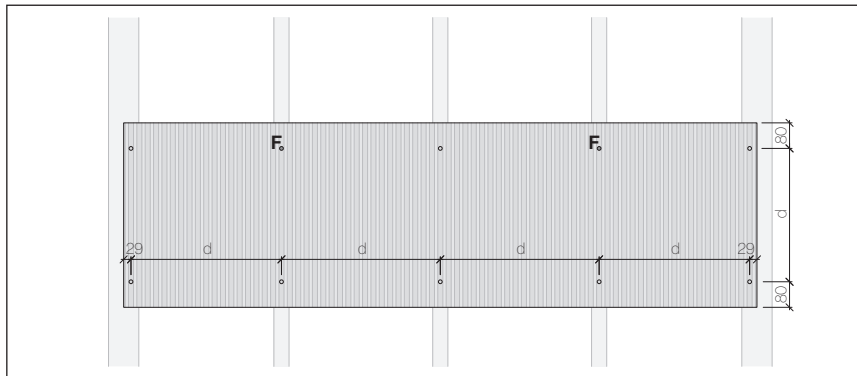

- Fixed point
 - Sliding point
- $\varnothing 9.5$ mm [F]
 $\varnothing 9.5$ mm

Design I **Metal supports**

Swisspearl Largo Gravia

Sample rivet layouts, final layout to be determined by a local structural engineer.

Swisspearl Largo horizontal panel (landscape) for even number of rivets

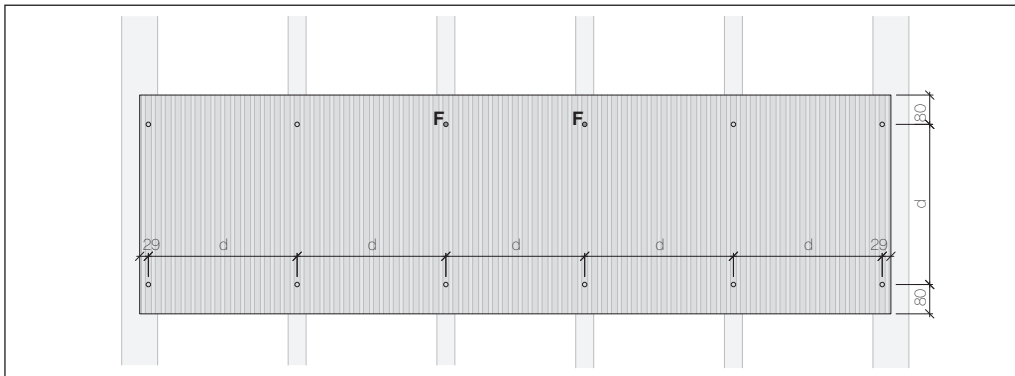
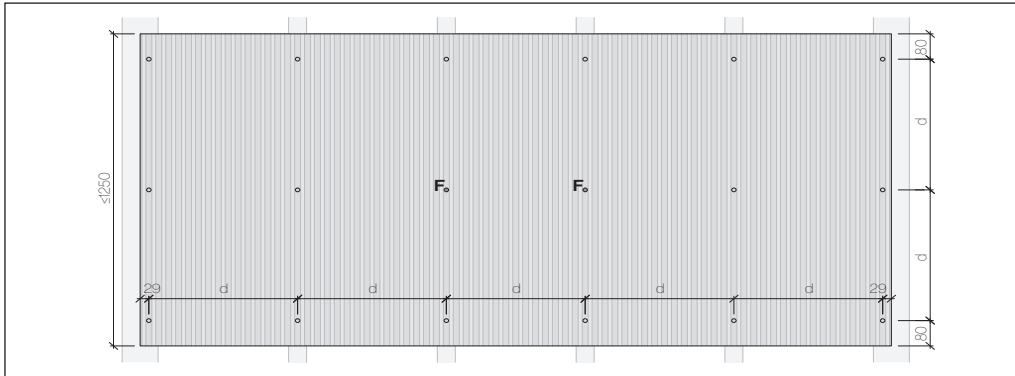

● Fixed point
○ Sliding point

Ø 9.5 mm [F]
Ø 9.5 mm

Example outer corner

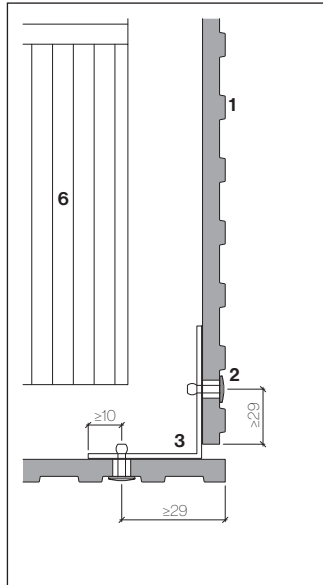

Example inner corner

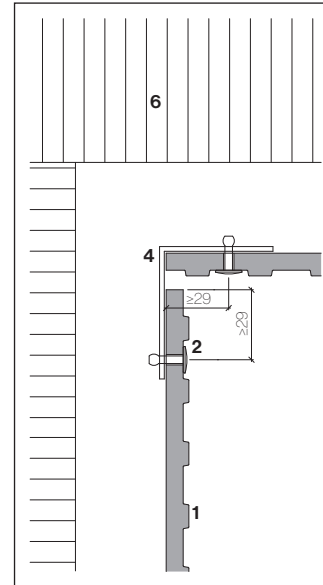
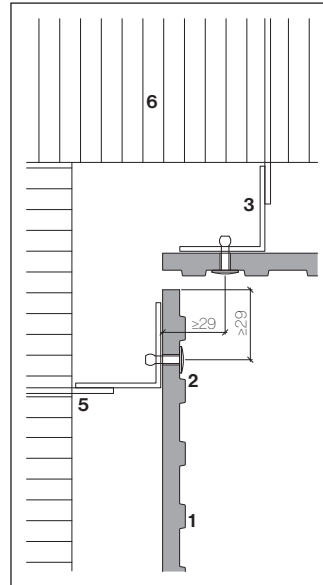

- 1 Swisspearl Largo Gravia 9/12 mm
- 2 Rivet 4.0 × 18-K15
- 3 Min. angle 60 × 60 mm
- 4 Min. angle 70 × 60 mm
- 5 Bracket
- 6 Thermal insulation

Corner angle not attached back to building as shown can be cantilevered up to 400 mm

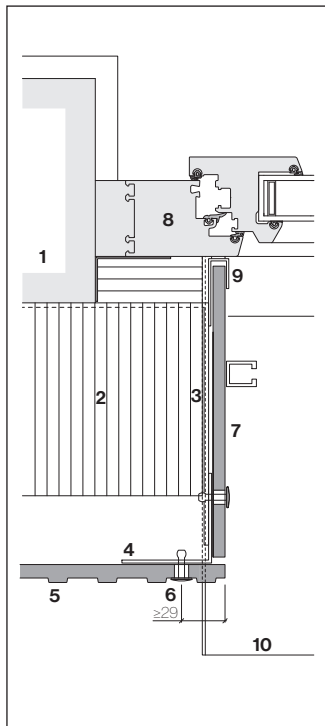
Example window jamb

Jamb with 8 mm panel

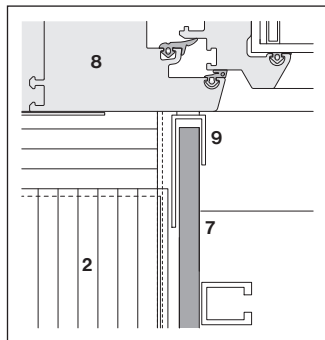

Window jamb with metal frame

- 1 Exterior wall
- 2 Thermal insulation
- 3 Horizontal support
- 4 Vertical support
- 5 Swisspearl Largo GraviaI 9/12 mm
- 6 Rivet 4.5 × 18 K15
- 7 Swisspearl Largo jamb board 8 mm
- 8 Window frame
- 9 U or F-profile with sealant
- 10 Window sill

Example window sill

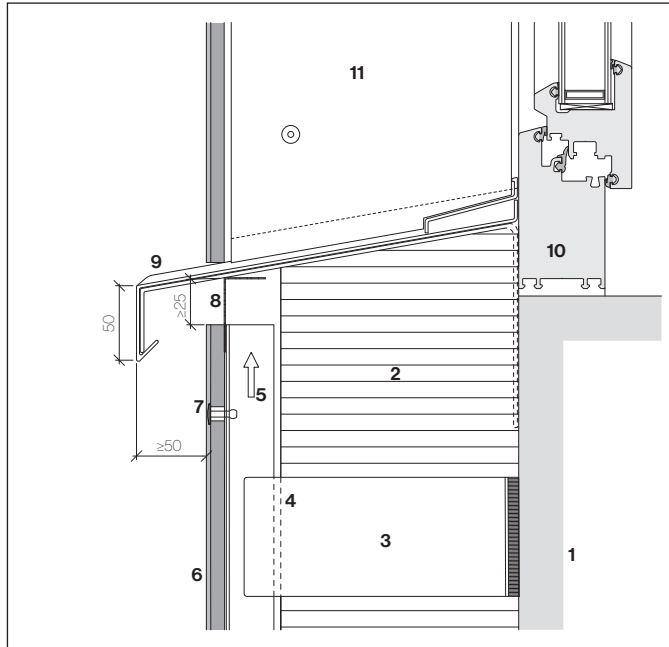

Window sill made of metal

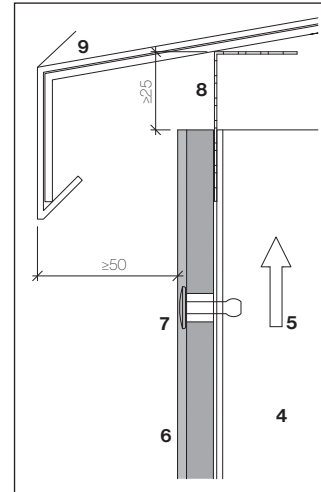

Sill detail

- 1 Exterior wall
- 2 Thermal insulation
- 3 Bracket
- 4 Vertical support
- 5 Ventilation cavity
- 6 Swisspearl Largo Gravia 9/12 mm
- 7 Rivet 4.0 × 18-K15
- 8 Perforated angle
- 9 Window sill
- 10 Window frame

Example window head

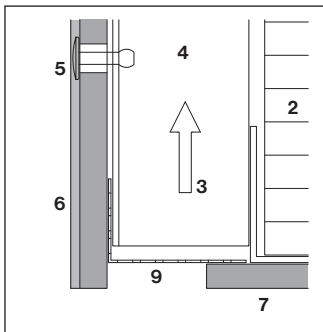

Perforated angle

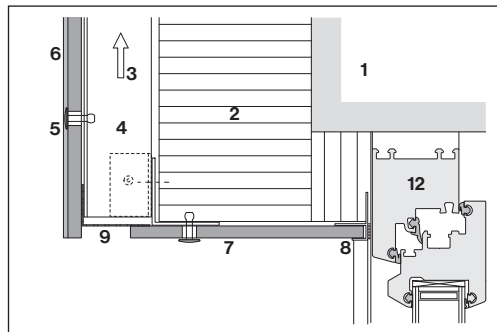

Metal framing around whole window

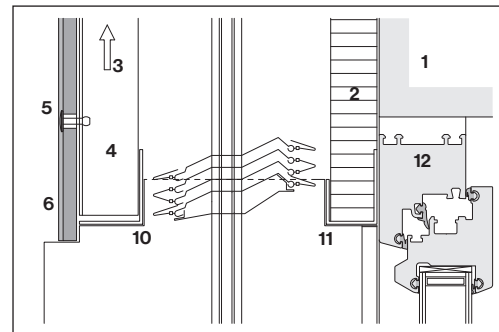

Head detail sun shutter

- 1 Exterior wall
- 2 Thermal insulation
- 3 Ventilation cavity
- 4 Vertical support
- 5 Rivet 4.0 × 18-K15
- 6 Swisspearl Largo GraviaI 9/12 mm
- 7 Swisspearl Largo 8 mm

- 8 U or F-profile
- 9 Perforated angle
- 10 Reinforcing profile
- 11 Angle profile insulation
- 12 Window frame

Example bottom detail

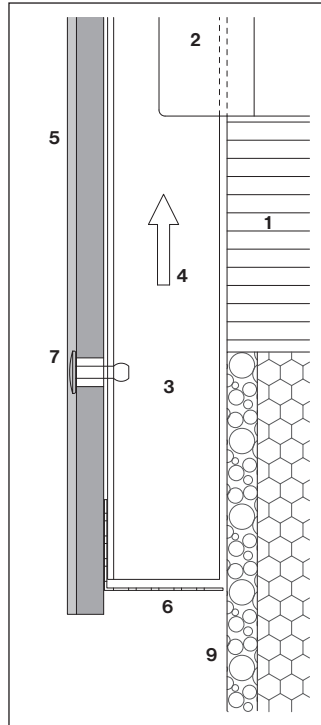
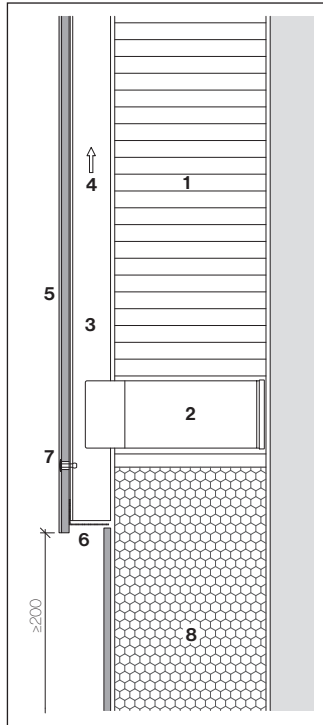

- 1 Thermal insulation
- 2 Bracket
- 3 Vertical support
- 4 Ventilated cavity
- 5 Swisspearl Largo Graviat 9/12 mm
- 6 Perforated angle
- 7 Rivet 4.0 × 18-K15
- 8 Thermal insulation
- 9 Thermal insulation water resistant

In order to avoid damages its advised to keep a minimum distance of 200 mm from bottom of the panel to the ground

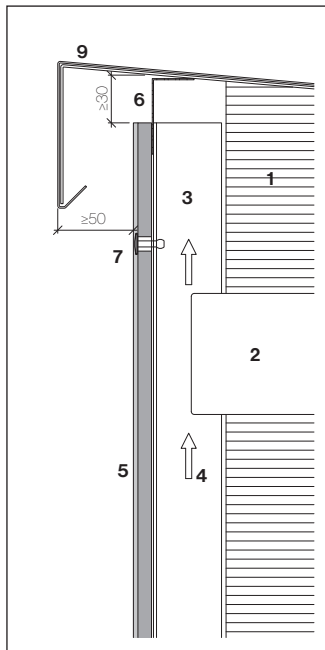
Example coping detail

Coping detail

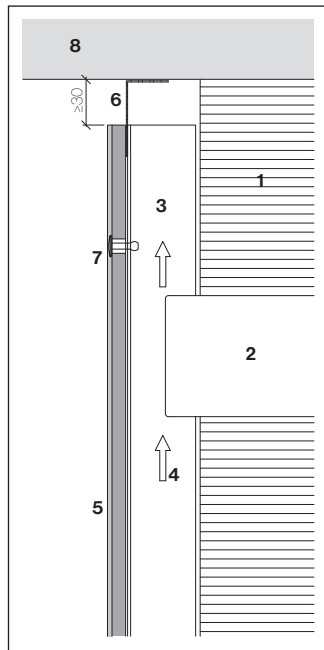

Details under slab

- 1 Thermal insulation
- 2 Bracket
- 3 Vertical support
- 4 Ventilated cavity
- 5 Swisspearl Largo Gravia 9/12 mm
- 6 Perforated angle
- 7 Rivet 4.0 × 18-K15
- 8 Soffit
- 9 Coping

Swisspearl screw

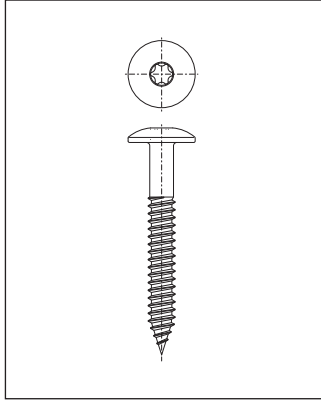

Swisspearl screw, stainless steel, saucer head \varnothing 12 mm, T20 drive, 4.8 x 38 mm.

Distances to panel edge

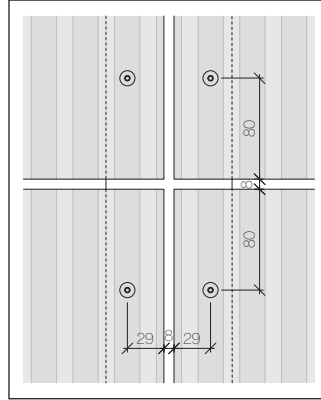

Panel hole

Diameter 5.5 mm

Standard edge distances

Horizontally 29 mm

Vertically 80 mm

Minimum edge distances

Horizontally 29 mm

Vertically 60 mm

Maximum edge distance

Horizontally and vertically max.

100 mm

Panel joints

Typical panel joint is 8 mm, this allows panel scraps to be used as spacers. Wider joints will make any inaccuracies in the installation less noticeable.

Installation

The screws must be installed with depth stop at 90 degrees set to the panel. The screw head must rest even to the panel.

Sub-frame engineering

Engineer / contractor are responsible for the design and installation of all sub framing parts including all pertaining fasteners.

Timber battens

Straight grown pine, dry (max. 20% moisture content).

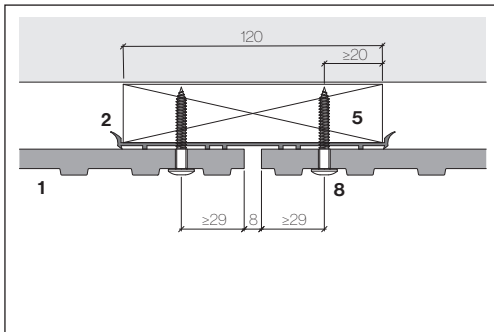
Fastening on timber battens

Timber Battens 120 mm
Continuous Graviat grid

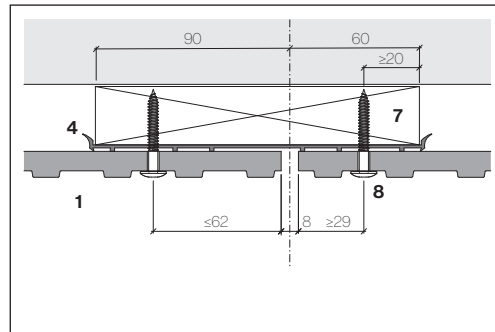

Timber battens 150 mm
Individual Graviat grid

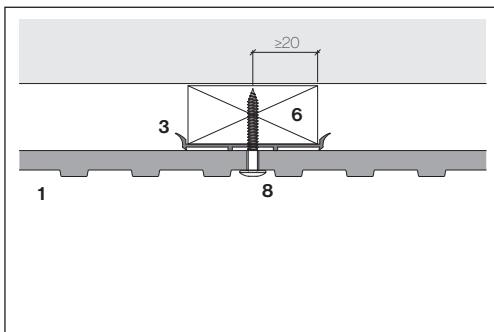

Timber Battens 60 mm
Continuous Graviat grid

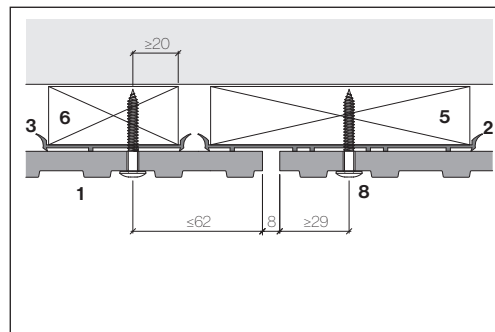

Timber battens 120 mm and 60 mm
Individual Graviat grid

- 1 Swisspearl Largo Graviat 9/12 mm
- 2 EPDM band 120 mm
- 3 EPDM band 60 mm
- 4 EPDM band 150 mm
- 5 Battens 27 × 120 mm
- 6 Battens 27 × 60 mm
- 7 Battens 27 × 150 mm
- 8 Screw T20 4.8 × 38 mm

Shock training

With individual vertical joints you have to use the vertical butt (120 mm 150 mm) by 30 mm to the division axis.

Panel planning

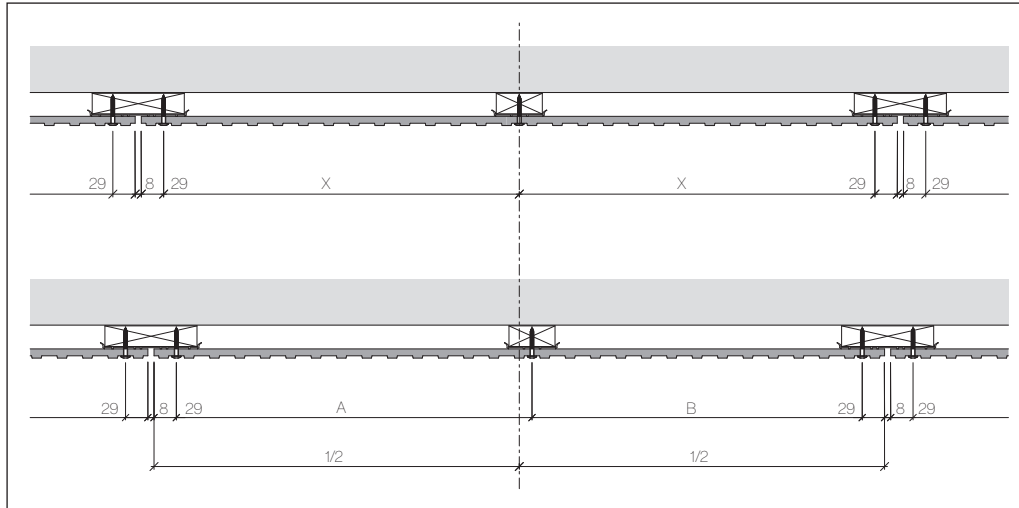

Jobsite fabrication

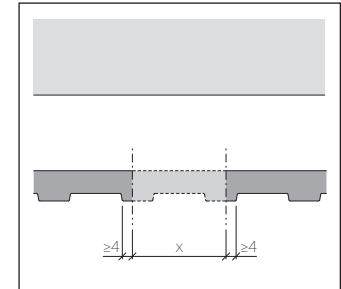

Onsite Gravial fabrication

Gravial cutting

When Gravial panels are cut on site, please note that minimum edge distance of 4 mm remains.

All cut edges must be afterwards treated with Luko sealant.

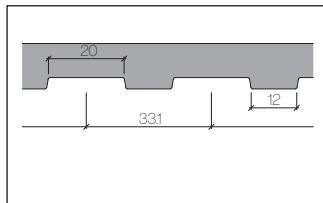

Detail engraving Gravial grid

Installation planning

The arrangement of the sub-frame will always depends on the grid of the engraving.

Calculation example:

Panel width minus lateral edge distance due to raster engraving = number of millings

Even = X

Uneven = A; B

Timber battens

Installation over timber battens is allowed provided the design meets local engineered codes and standards.

Timber quality

Battens must be thickness gauged to 1 face:

- Thickness min. 27 mm (min. 3/4")
- Always use planed surface timber
- Solidity class II (FK II/C24)
- Recommended only using kiln-dried lumber
- Moisture content max. 20-%
- Timber must be of equal or higher quality

Vertical battens

At panel joints:

2 × 27 × 60 mm or

1 × 27 × 120 mm

Intermediate supports:

27 × 60 mm

Engineering

Battens including their attachment to be engineered per local standards.

Battens screw

Screw Ø min. 6 mm

Head Ø min. 12 mm

For battens wider than 60 mm use two screws per point of attachment. Rear ventilation, thermal insulation, moisture proofing, wind proofing layers. All local standards are applicable and must be complied with.

Joint flashing

Horizontal joint and L-flashing should be 2 mm shorter than panel and thus not visible in vertical joints. If required butt joint the flashings on any batten, do not overlap flashing.

L-flashings and horizontal joint flashing are not 100% waterproof! Therefore all timber battens must be fully covered by EPDM bands to protect them against moisture and to prevent rotting and the growth of fungi and mold.

EPDM strips

All timber battens must be fully covered by EPDM backing strips stapled to the battens. Stapled at the edges of the bands. EPDM strips to be in one single piece top to bottom or overlapped as per diagram.

Horizontal panel joint

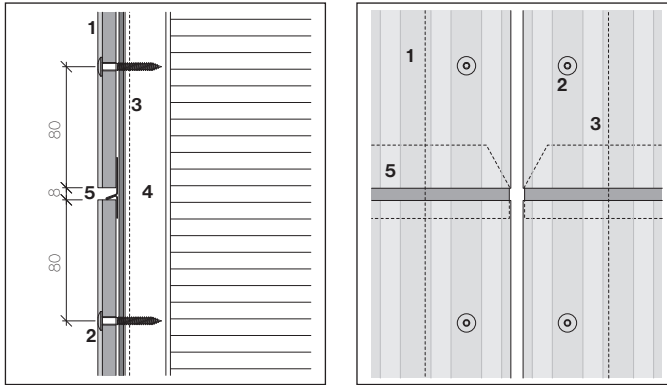

EPDM joints

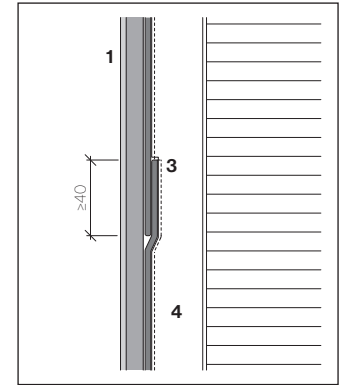

Horizontal section through vertical battens

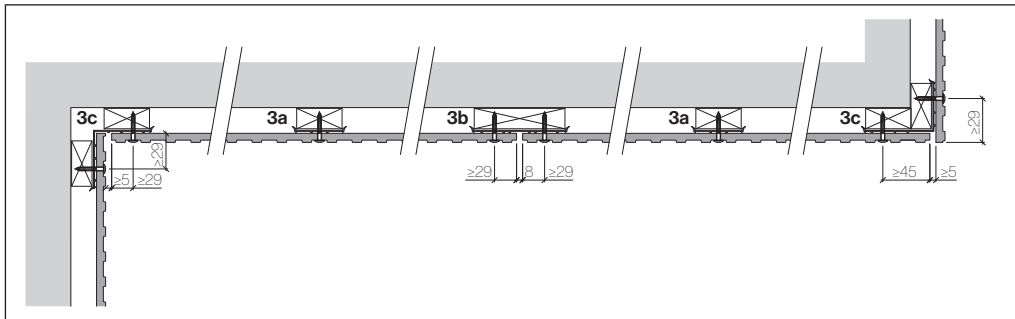

Butt joints with EPDM bands should be avoided if possible. Should the formation of butt joints be unavoidable, the batten must be released 3 mm and the overlap of the band be 40 mm.

- 1 Swisspearl Largo Gravia 9/12 mm
- 2 Screw
- 3a EPDM band 60 mm
- 3b EPDM band 120 mm
- 3c EPDM band 150 mm
- 4 Batten 27 × 60, 27 × 120 mm
- 5 Joint flashing

Vertical joint at window

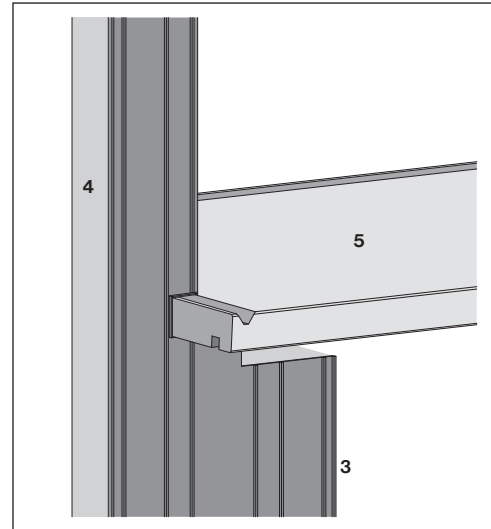
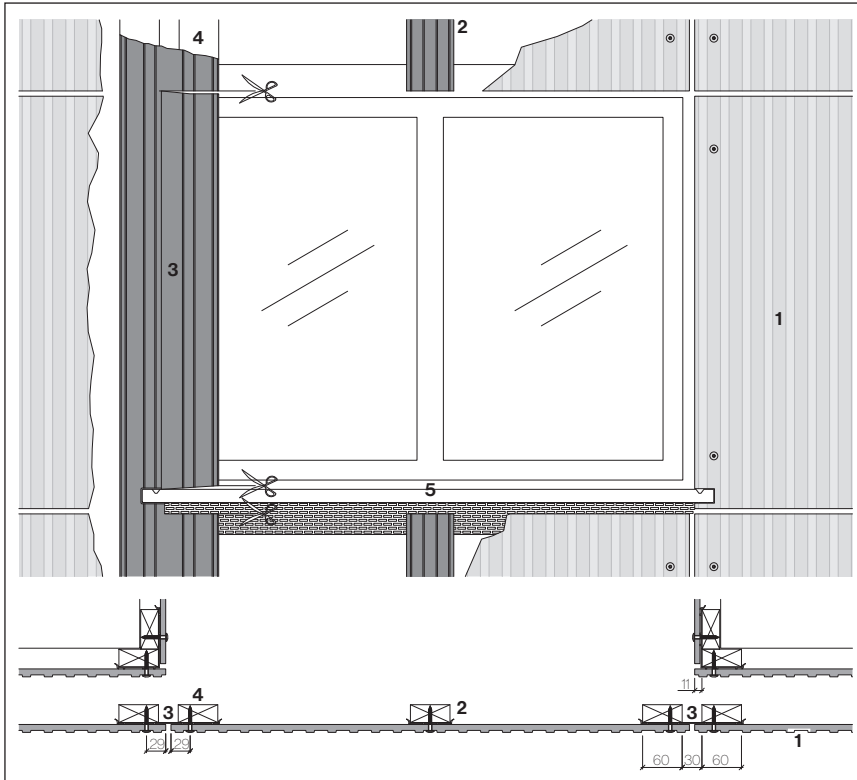

- 1 Swisspearl Largo Gravia 9/12 mm
- 2 EPDM band 60 mm
- 3 EPDM band 150 mm
- 4 Batten 27 × 60 mm
- 5 Swisspearl window sill

Timber battens - Gravia! 9/12 mm façade panels – screw distances

Characteristic value of wind suction (according to European standards)		Design value of wind suction (including a chosen safety coefficient of 1.5)		Recommendation for maximal spacing d (distance between rivets or screws)			
kN/m ²	psf	kN/m ²	psf	Vertical panel (portrait)		Horizontal panel (landscape)	
				horizontally	vertically	horizontally	vertically
				mm	mm	mm	mm
-0.70	-13.90	-1.0	-20.9	600	725	725	530
-1.00	-20.90	-1.5	-31.3	600	590	675	530
-1.30	-26.50	-1.9	-39.7	600	490	520	530
-1.80	-37.60	-2.7	-56.4	400	490	430	370
-2.30	-48.70	-3.5	-73.1	400	420	400	370
-2.70	-55.70	-4.0	-83.5	400	330	370	370
-3.30	-69.60	-5.0	-104.4	300	370	370	280
-4.00	-83.50	-6.0	-125.3	300	330	330	220

Above table is a guide line for 2 or more fasteners in vertical and horizontal direction. The spacings originate from 1230 × 3050 mm full size panels with equal distances between screws. Data may be interpolated.

Engineering responsibility

The spacings in above table are provided as indication. For the actual cladding design a locally licensed engineer shall assume responsibility for calculation and verification.

Panel data

- Modulus of elasticity
MOE ca. 15'000 MPa
- Characteristic value of bending strength (average: lengthwise / crosswise) or MOR (average) 22,4 MPa
- Density > 1.8g/cm³

Characteristic values**Resistance of screws 4.8 × 38 Ø 12 mm**

Position	Distance between fasteners (spacing)
	600 mm
Middle	2350 N
Edge	1300 N
Corner	900 N

The data was evaluated according to ETAG 034 using 9/12 mm GraviaI panel, and includes no safety factor. Diameter of panel hole must be 5.5 mm, and screw head must be 12 mm. Minimum screw engagement in timber to be 27 mm. Edge distances 29 mm horizontally, 80 mm vertically. The data may be interpolated.

Single span panel (no intermediate support)

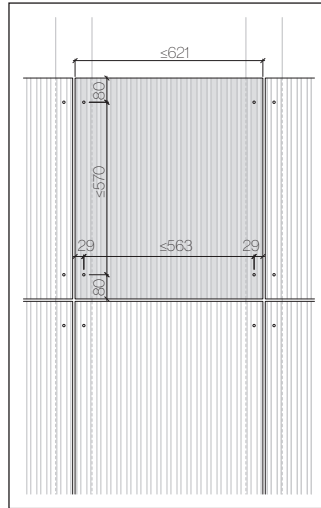
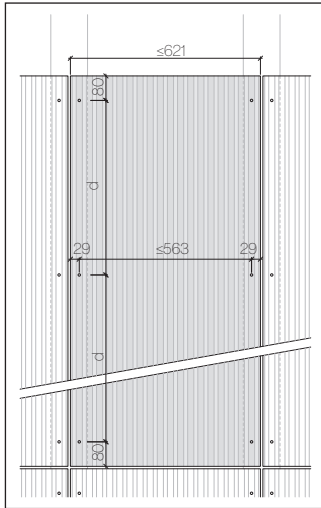

Soffit panels

Fastener distances for soffit panels and suspended ceilings not to exceed 500mm.

Max. distance between fasteners for single span panels 563 mm, unless smaller distance is required by high wind load as per table of fastener distances.

Sample screw layouts, final layout to be determined by a local structural engineer.

Swisspearl Largo vertical panel (portrait)

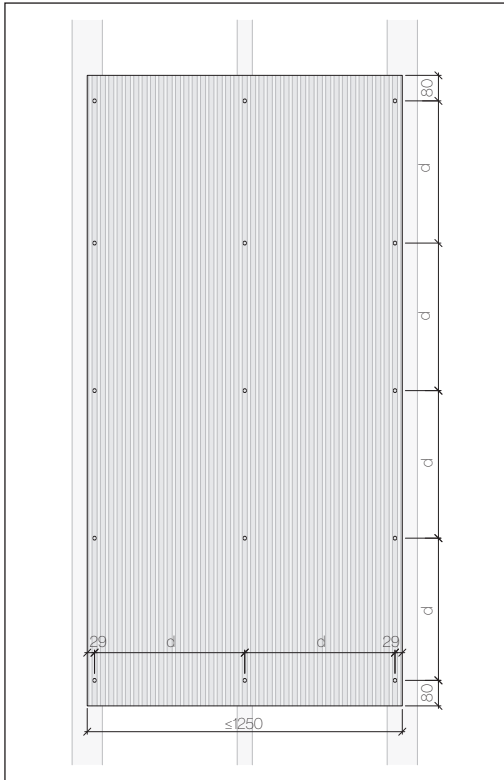

Swisspearl Largo horizontal panel (landscape)

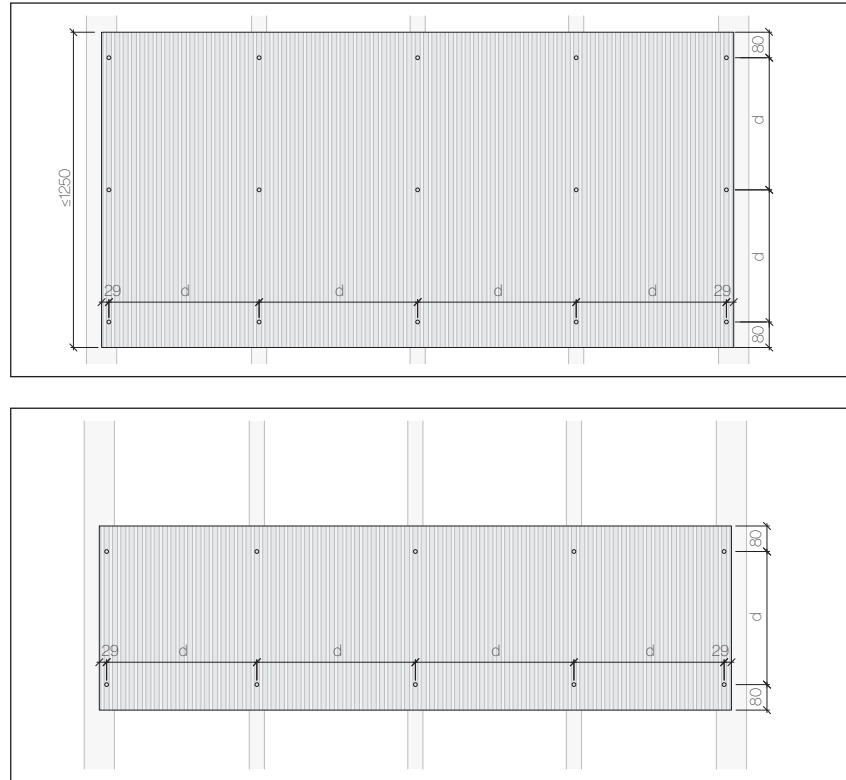

Drill holes $\varnothing 5.5$ mm

Swisspearl Largo example outer corner

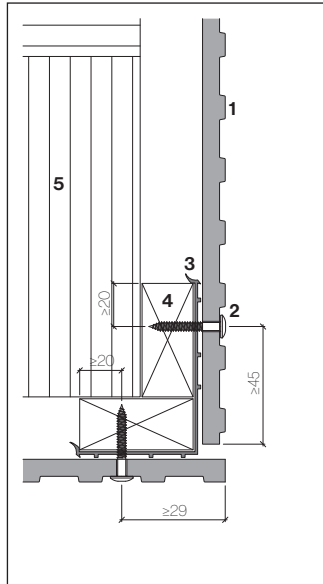

Batten configuration to building corner as shown above with the use of 150 mm EPDM.

Swisspearl Largo example inner corner

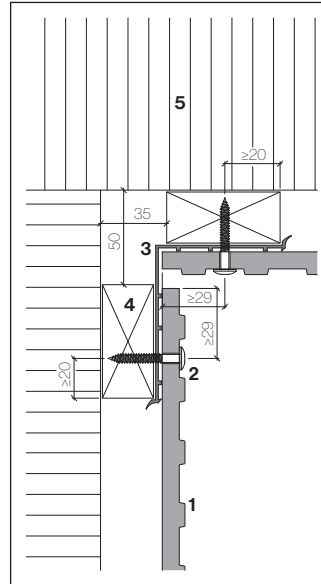

- 1 Swisspearl Largo Gravia 9/12 mm
- 2 Swisspearl Screw 4.8 × 38 mm
- 3 EPDM band 150 mm
- 4 Batten 27 × 60 mm
- 5 Thermal insulation

Example window jamb

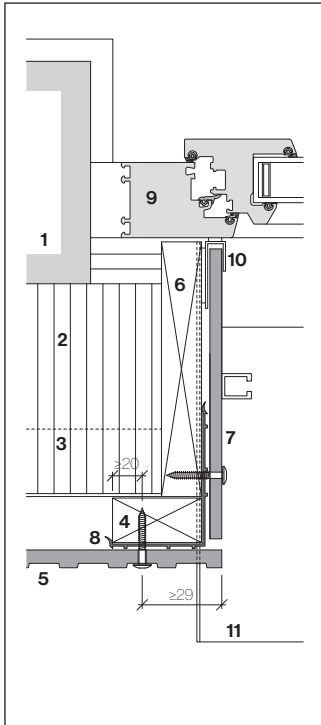

Jamb with 8 mm panels

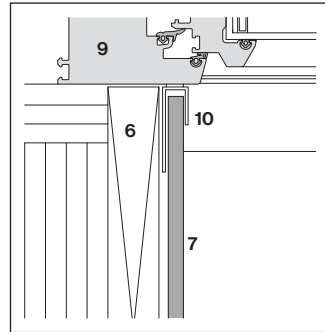

Window detail

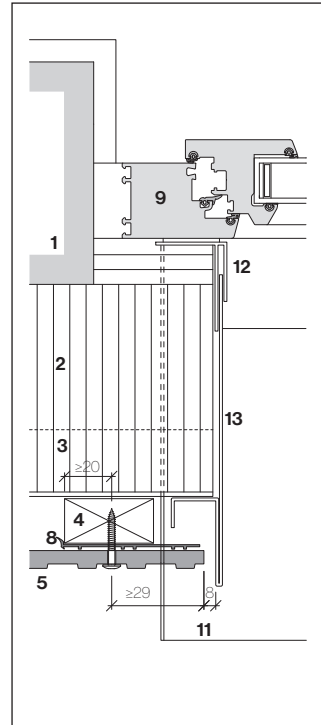

- 1 Exterior wall
- 2 Thermal insulation
- 3 Horizontal support
- 4 Vertical support
- 5 Swisspearl Largo GraviaI 9/12 mm
- 6 Jamb board
- 7 Swisspearl Largo jamb board 8 mm
- 8 EPDM band 150 mm
- 9 Window frame
- 10 U or F-profile
- 11 Window sill
- 12 F-profile connection with seal
- 13 Plug frame

Example window sill

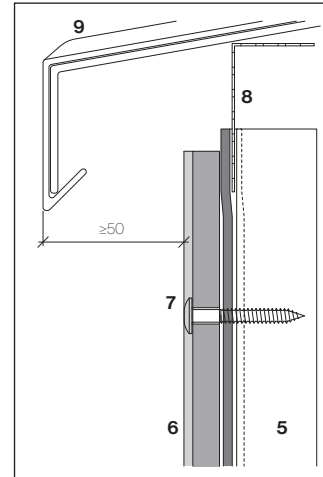
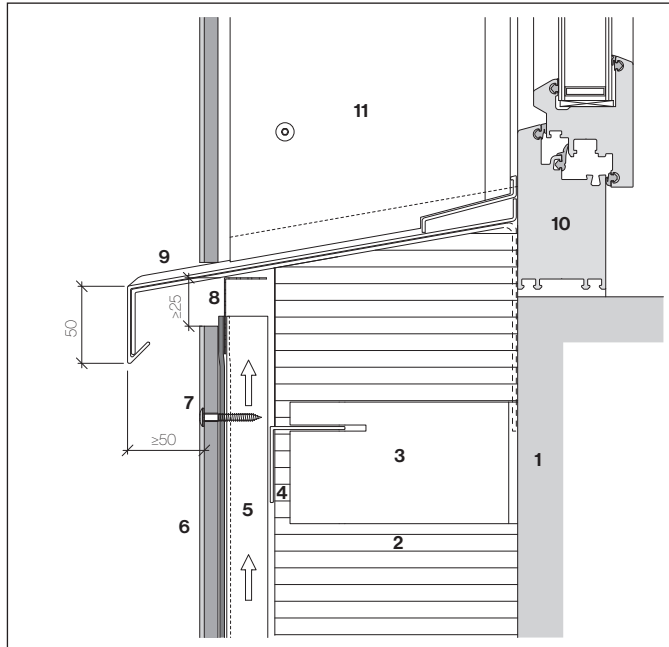

Sill detail

- 1 Exterior wall
- 2 Thermal insulation
- 3 Vertical support
- 4 Horizontal support
- 5 Vertical support
- 6 Swisspearl Largo Graviol 9/12 mm
- 7 Screw 4.8 × 38 mm
- 8 Perforated angle
- 9 Window sill
- 10 Window frame

Window sill made of metal

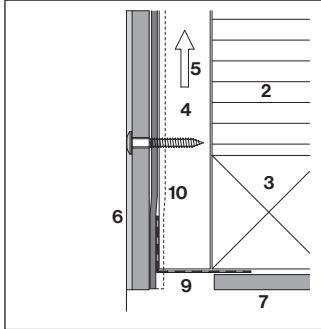
Example window head

Perforated angle

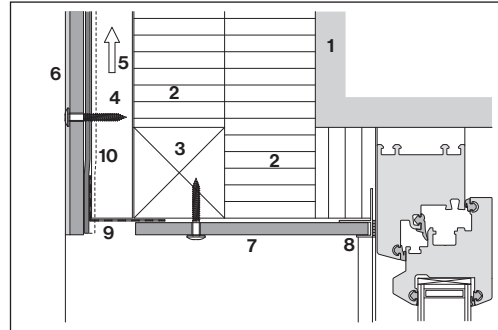

Metal framing around whole window

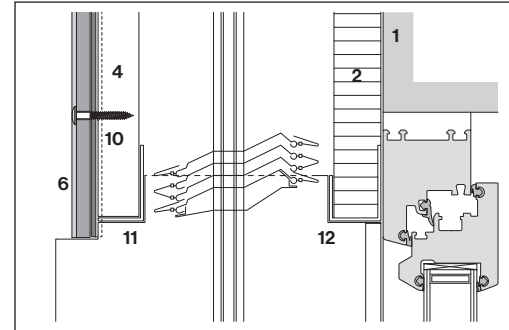

Head detail sun shutter

- 1 Exterior wall
- 2 Thermal insulation
- 3 Horizontal support
- 4 Vertical support
- 5 Ventilation cavity
- 6 Swisspearl Largo Graviai 9/12 mm
- 7 Swisspearl Largo 8 mm

- 8 U or F-profile with sealant
- 9 Perforated angle
- 10 EPDM band
- 11 Angle profile
- 12 Angle profile insulation

Example bottom detail

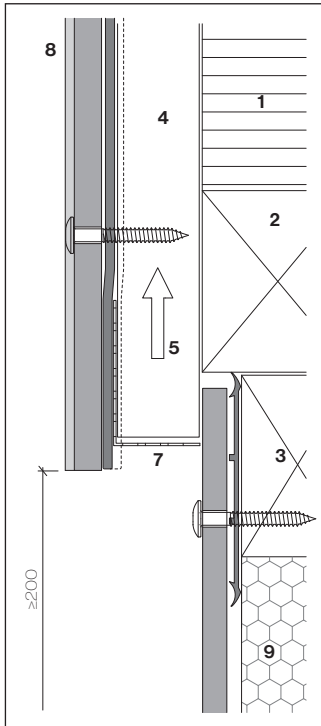

Timber / timber

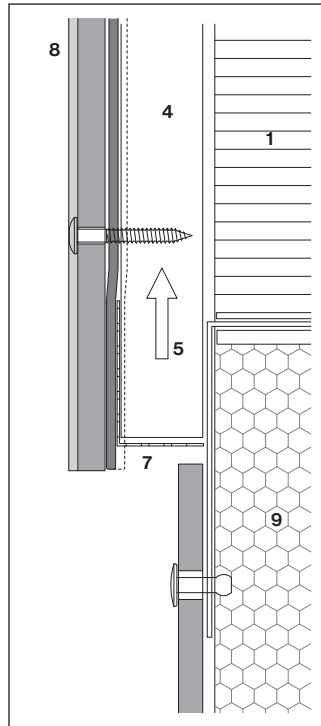

Timber / metal

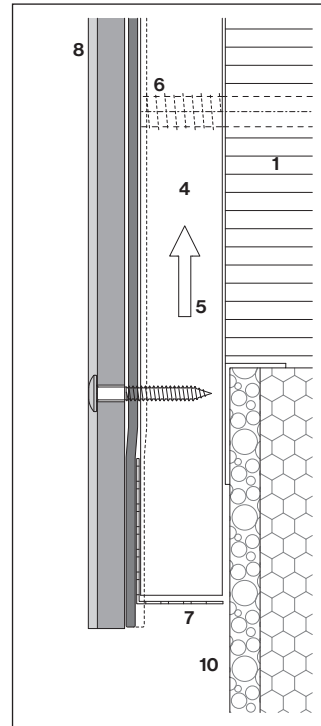

Timber verticals with
spacer screw

- 1 Thermal insulation
- 2 Horizontal batten
- 3 Horizontal support
- 4 Vertical support
- 5 Ventilated cavity
- 6 Spacer screw
- 7 Perforated angle
- 8 Swisspearl Largo Graviat 9/12 mm
- 9 Thermal insulation water resistant
- 10 Thermal insulation

Example coping detail

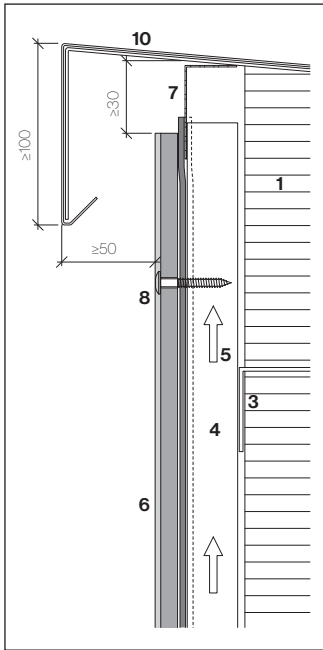

Coping detail

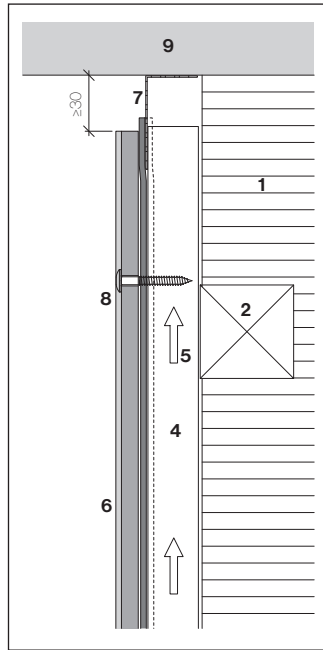

Detail under slab

- 1 Thermal insulation
- 2 Horizontal batten
- 3 Horizontal support
- 4 Vertical support
- 5 Ventilated cavity
- 6 Swisspearl Largo Graviat 9/12 mm
- 7 Perforated angle
- 8 Screw
- 9 Soffit
- 10 Coping

On site storage

Pallets must be stored under cover i.e. out of rainfall and direct sunlight. Where this is not possible, store under tarp. Ingress of water into stacked panels will cause permanent staining to panel surface. Excess heat to stacked panels can cause damage to panel surface. Overseas pallets can be stacked several above another.

Provisional roofing or tarp covers are to be used in a manner that allows cross ventilation as shown.

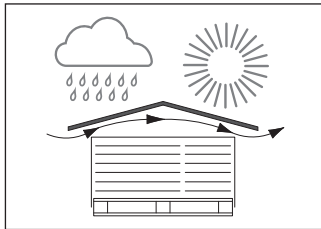

Fabricating panels at local fabricators or on site

Always work out of the weather. Cutting panels to size:

- Use industrial vertical panel saw for large quantities
- For small quantities use circular hand saw with straight edge and dust extraction
- Panel cut outs, etc. use jig saw
- Cutting blade supplied by factory or procured locally; considering cutting quality, performance, costs
- Dust from fabricating on site must be removed immediately
- Avoid tools which produce fine dust

Stacking panels on site

- Always stack the panels horizontally on pallet base
- Each stack should not be more than 500 mm high (1' 18")
- Use foam protection layer between the panels (as supplied by factory)
- 5 stacks on top of each other

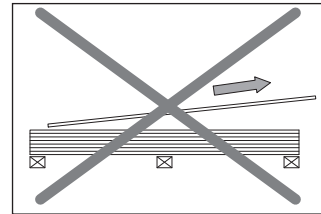

Do not pull panel across...

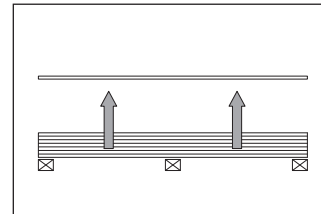

...but lift up vertically

Panel fabrication on site

For long cuts use multifunction table with circular hand saw, guide rail and dust extractor. Saw blade supplied by panel manufacturer or at own choice.

Cut outs

For smaller cut outs or odd shapes use pendular jig saw. For drilling use spiral drill bits on site storage $\varnothing 9.5 / \varnothing 5.5$ mm (metal / timber supports) with carbide metal tips supplied by panel manufacturer or procured locally.

Sealer to cut edges

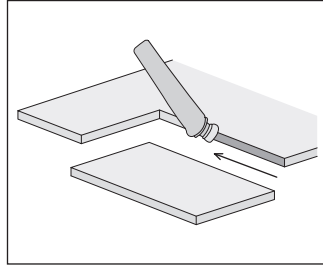

All cut edges must be sealed with impregnation liquid LUKO. Immediately wipe LUKO off the face of the material.

LUKO hand applicator

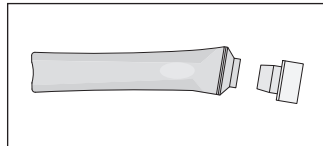

LUKO filled in hand applicators is frost proof to -8°C (18°F). LUKO supplied in 1 liter bottles is not frost proof but dries faster (for fabrication in work shop).

Tools

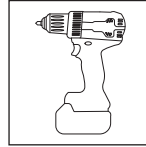

Drill

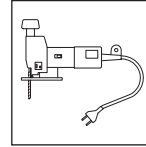

Jig saw

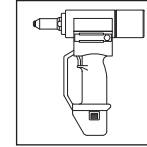

Rivet gun

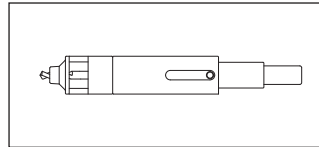

Center drill gauge

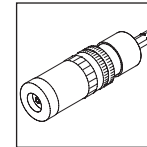

Depth stop Gravial (mandatory for timber sub-frame)

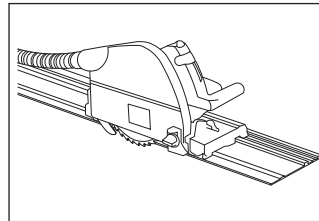

Circular hand saw with guide rail and dust extraction

Swisspearl panels including

Including those panels with an added Façade and or Roof coatings fall into these categories.

Cleaning procedures

Remove dust immediately after fabricating panels.

Dry dust

To be removed with a vacuum cleaner, or with a clean, dry and soft cloth or brush.

Wet dust

Results in staining the panel surface. It must be removed immediately, using plenty of water and a sponge or soft brush.

Cleaning of completed claddings

Non calcium based stains:

- Use high pressure cold water at max. 80 bars (minimum distance from panel 25 cm/10"). Use flat fan spray nozzle, dirt blasters are not allowed. Prior do test on in- conspicuous part of cladding
- If required use mild soap or dish-washing liquid. Do not use abrasive or solvent containing cleaning agents
- Do not use glass cleaning detergents!
- Never wash claddings in direct sun light with alkaline or acid cleaners, as the detergent may cause irreversible stains

Calcium based stains:

- Apply a mist spray of a solution of 9.5% acetic acid and water
- Allow to react a few minutes but do not let dry out
- Use high pressure cold water to rinse cladding

Repeate steps 1 to 3 on difficult stains:

Cleaning during service life

Normally no cleaning will be needed since the rain will periodically wash away dust, environmental dirt, etc. However, if particular environmental conditions lead to a dirty surface, wash with garden hose or high pressure cold water.

The installation of Graviaal panels is thought as vertical grids, in order to avoid dust sitting on the engravings. Should a horizontal grid be considered, technically possible, keep in mind that dust might sit and stain the panels.

Organic growth

Remove algae / fungii with a 5% solution of hydrogen peroxide (H₂O₂) to eliminate all spores.

Masking tape

For the use of masking tape on panels it should be noted that most common masking tapes are not resistant to UV rays. Such tapes leave behind residues, that cannot be removed without causing damage to panel surface. However the use of the following masking tapes is recommended:

- Masking tape 3M Blue 2090 for temporary application (1 - 2 weeks)
- Masking tape 3M Gold 244 for longer term application.

